

HOIST OPERATION QUICK REFERENCE

PC3 1000/1500 SERIES HOISTS

READ THE OPERATIONS MANUAL BEFORE USING THIS QUICK REFERENCE

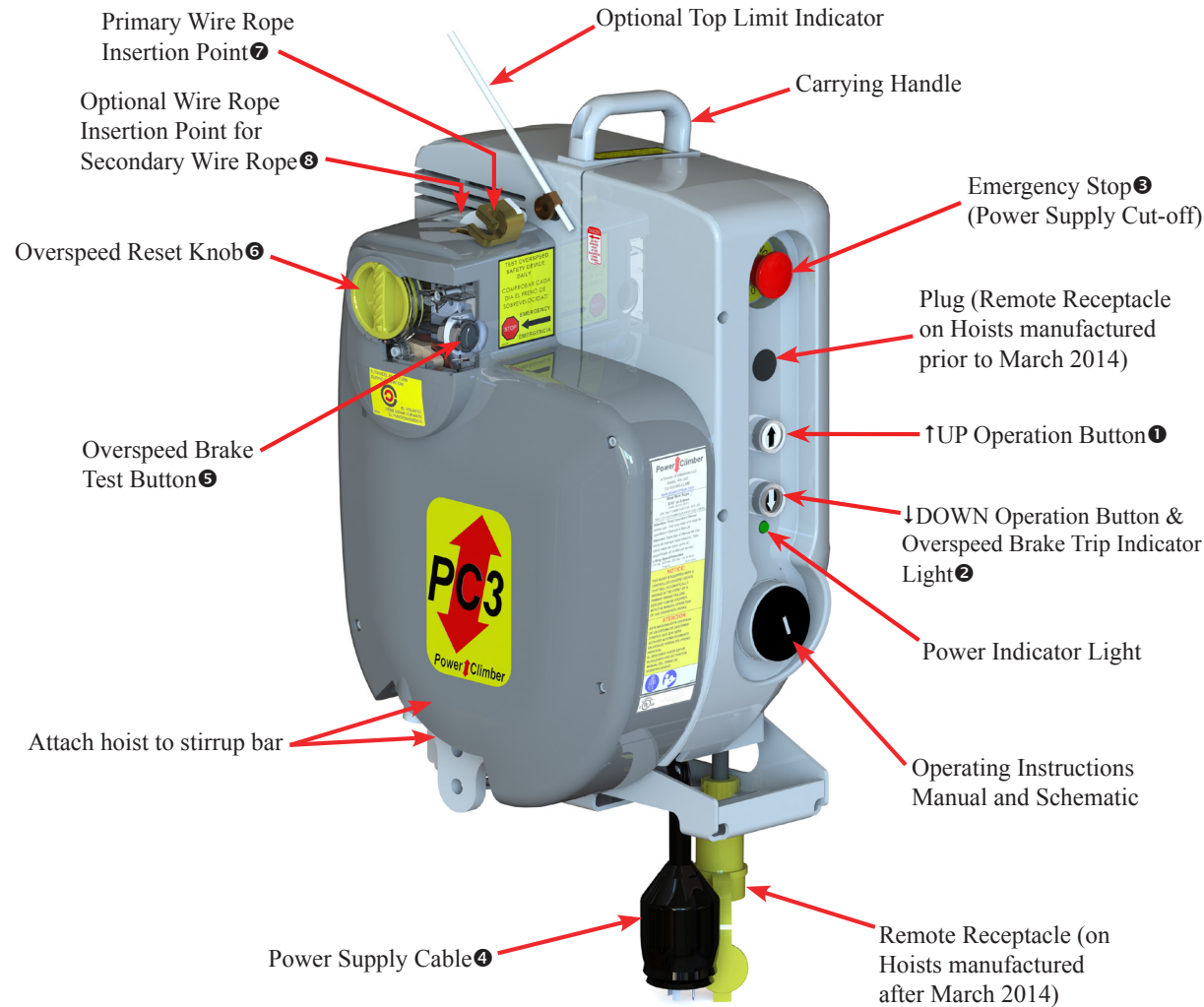

Model Designation and Serial Number



NORMAL OPERATION

- For routine travel in the ↑UP direction, push in the ↑UP operation button ①.
- For routine travel in the ↓DOWN direction, push in the ↓DOWN operation button ②.
- Both buttons are spring-loaded and will return to the OFF position AND apply the brake when released.
- **If the hoist does not immediately stop, press the emergency stop ③ AND the overspeed brake test button ⑤. Unplug the power supply cable ④.**
- Perform daily testing and inspection (see over) to ensure safe and correct operation. Do NOT use the hoist for lifting until it has successfully completed the daily tests.

REEVING

- Push the primary suspension wire rope through the primary suspension wire rope insertion point ⑦ approximately 15 inches.
- Operate the hoist in the ↑UP direction while pushing the rope into the hoist.
- Ensure the wire rope runs freely through the wire rope exit guide ⑩.
- If the hoist is equipped with an optional secondary suspension wire rope, push the secondary suspension wire rope through the secondary suspension wire rope insertion point ⑧ until it exits the hoist.
- Attach a 25 lb (11.5 kg) weight to the end of the secondary wire rope to assist secondary wire rope travel.

Optional Secondary Suspension Wire Rope Insertion Point ⑧

Primary Suspension Wire Rope Insertion Point ⑦

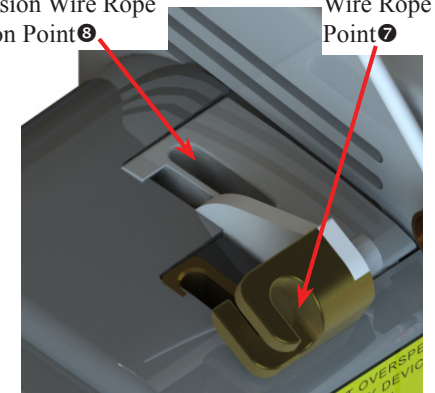

DEREEVING PRIMARY SUSPENSION WIRE ROPE

For hoists equipped with the optional secondary wire rope, the secondary wire rope must be removed before the primary wire rope is removed.

- **WARNING!** To prevent hoists and platform from tipping and avoid injuries, ensure that the platform is properly supported on a stable, flat surface before putting slack on the primary suspension wire rope.
- Push in the ↓DOWN operation button ② to wind the primary suspension wire rope out of the hoist. To remove the last 15 inches (40 cm) of wire rope, if necessary, grab the wire rope above the primary suspension wire rope insertion point ⑦, hold the overspeed brake reset knob ⑥ in the reset position (vertical) and slowly pull the primary suspension wire rope out of the hoist.

DEREEVING SECONDARY SUSPENSION WIRE ROPE

- In order to remove the optional secondary suspension wire rope, there must be no slack on the primary suspension wire rope and the platform must be supported on a stable surface.
- Remove the counterweight from the end of the secondary suspension wire rope.
- Pull the secondary suspension wire rope out of the hoist by hand.
- If necessary, the primary suspension wire rope can now be removed from the hoist.

DAILY TESTING AND INSPECTION

- Before operating the hoist, inspect the following:
 - Wire rope
 - Power supply
 - Rigging
 - Platform
 - Hoist
 - All parts are present, in proper working order, and are not damaged.
 - Bolts, nuts, and clamps are well secured.
 - Ensure the hoist is secured to the stirrup with SAE Grade 5 fasteners and lock nuts that are properly installed.
- In a dirty environment that contains epoxy, paint, cement, sand blast residue, or corrosive material, inspect the operation of the overspeed brake several times a day. Protective hoist covers are recommended. Contact your supplier.

TEST THE OVERSPEED BRAKE

- While powering the hoist ↑UP and ↓DOWN approximately 3 feet (1 meter), look through the window into the overspeed compartment to see whether the flywheel is turning.



- Dereeve the wire rope:
- Re-insert the wire rope about 12" (30 cm) into the hoist.
- Holding the wire rope firmly, pull it out quickly. If the brake is working correctly, it will grab and hold the wire rope in less than 4" (10 cm). The ↓DOWN button will light up **RED** to indicate the overspeed brake has activated and the ↓DOWN circuit has been interrupted.
- Repeat this test at least 3 times. If the brake does not work correctly every time, **DO NOT USE THE HOIST**. Return the hoist to your supplier.
- Reset the overspeed brake by turning the overspeed brake reset knob ⑥ clockwise.



TEST THE OVERSPEED BRAKE TEST BUTTON

- Push in the ↑UP operation button ① and raise the platform approximately 3 feet (1 meter).
- Lift the Control Descent Lever. As the hoist begins to descend, push the Overspeed Test Button ⑨.
- The hoist **MUST** stop **IMMEDIATELY!**

TEST THE EMERGENCY STOP BUTTON

- While running the hoist in either direction, press the red emergency stop button ⑩.
- Once the emergency stop button ⑩ has been pressed, the hoist should not move at all.
- To reset the emergency stop button ⑩, pull the button out.

TEST THE CONTROLLED DESCENT

- Raise the platform approximately 3 feet (1 meter).
- Disconnect the power supply cable.
- Pull up the controlled descent lever ⑧ **SLOWLY**, to make sure the hoist does not overspeed. The platform should descend at a slow, controlled speed.

WARNING! If the overspeed brake trips while testing the controlled descent, the controlled descent system is not working properly and **THE HOIST SHOULD NOT BE USED**.