

The Collapsible Work Cage from PowerClimber™ is a lightweight, full size cage that disassembles with no tools, to pass through an 18 inch circular opening. Now one cage offers the load rating and deck space of a full size cage and the compact size and easy disassembly of a restricted access cage.

Collapsible Aluminum Work Cage (P/N 8-0124)

- PowerClimber™ dependability
- Compatible with Pocket Climber and most other hoist brands
- Lightweight aluminum extrusion
- Heaviest component is 60 lbs.
- Disassembles without hand tools to fit through an 18" opening

Disassembly:

- Remove hinged deck and hand rails
- Collapse mast
- Pass all through 18" circular opening

Optional Equipment

- Face Rollers (P/N 701037-1)
- Optional flydecks to provide 9 ft. long work space (P/N 700934-2)
- Casters

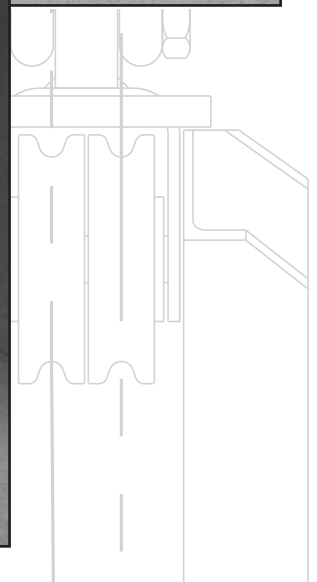
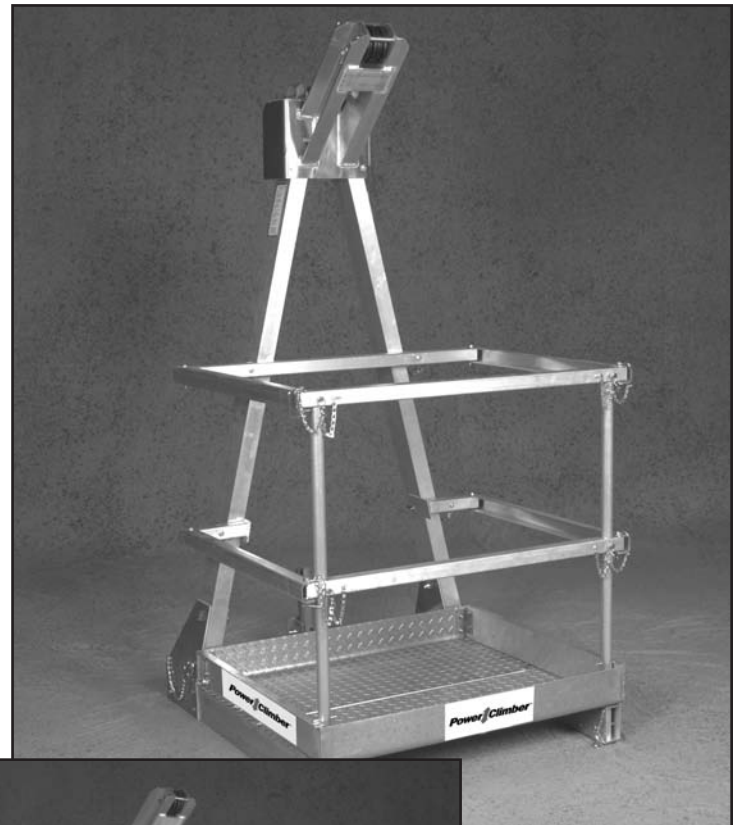

(Continued on back)
A Division of SafeWorks, LLC

More top of the line equipment at bottom line savings from Power Climber!

Specifications

- Maximum hoist rated capacity**1,000 lbs.
- Maximum live load**.....750 lbs.
- Maximum live load with flydecks**500 lbs.
- Unit weight with/without flydecks**250 lbs./150 lbs.
- Overall dimensions (in inches)**.....36^{3/8}w x 40^{1/2}d x 79^{1/2}h
- Work space dimensions**.....28w x 36d x 72h
- Overall dimensions with 3 ft. flydecks (in inches)**108^{3/8}w x 40^{1/2}d x 79^{1/2}h

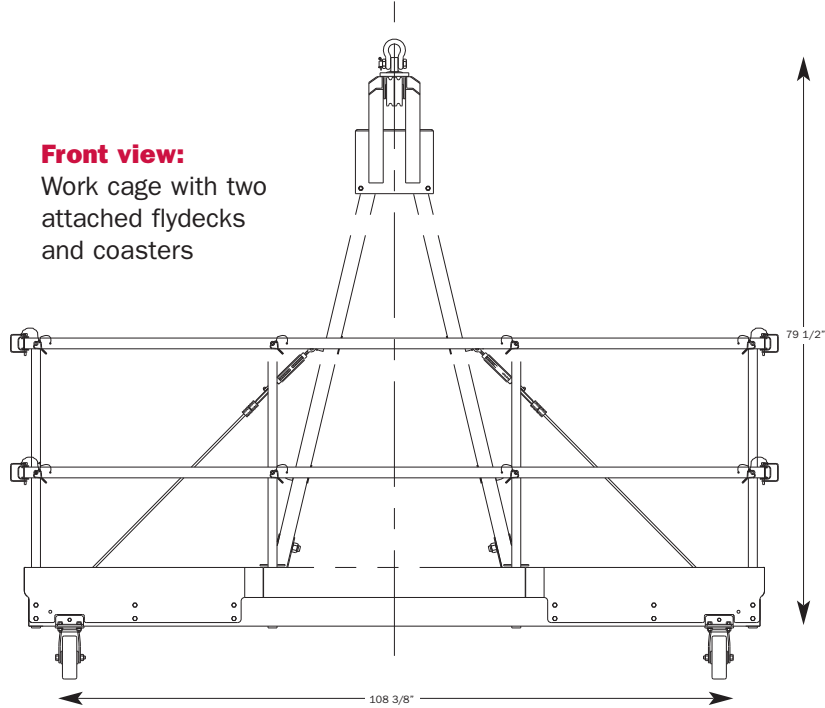
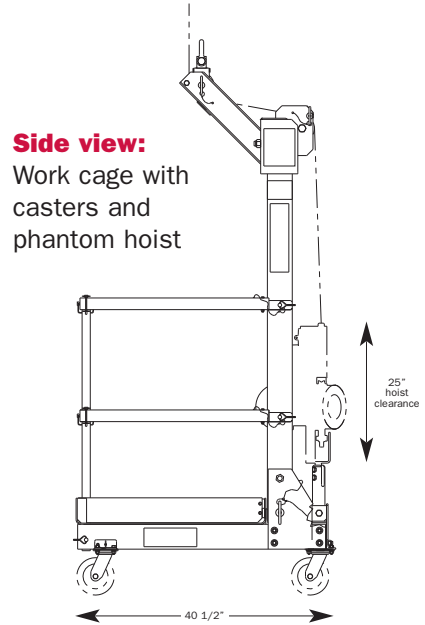
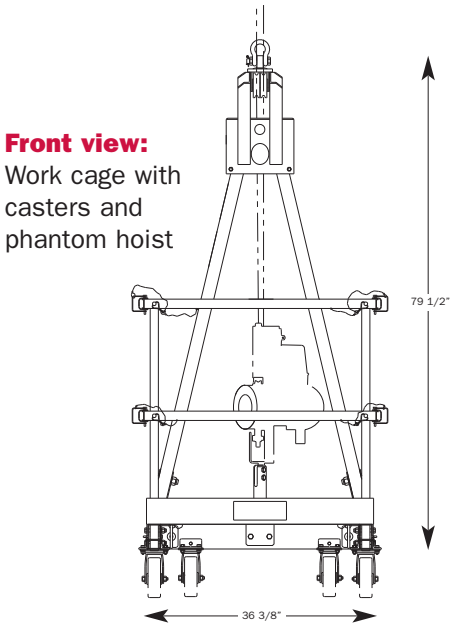

Load capacity verified by independent testing lab
Meets or exceeds current OSHA & ANSI requirements

Wear Fall Protection! It's The Law.

Power Climber™

a Division of SafeWorks, LLC is America's largest manufacturer of powered suspended scaffold hoists and accessories. Power Climber™ operates plants in the United States and Belgium, and has manufactured suspended scaffold equipment for over 25 years.

Corporate Headquarters

365 Upland Drive
Tukwila, Washington 98188
Phone: (206) 577-0101
Fax: (206) 575-6465
TOLL FREE: (800) 560-CLIMB (2546)
<http://www.PowerClimber.com>
E-mail: PowerClimber@SafeWorks.com

Distributors and representation opportunities worldwide.

Other Products Available from Power Climber™:

- Pocket Climber Hoists
- Astro Hoists
- Modular Platforms
- Work Cages
- Bosun's Chairs
- Rigging Devices
- Manual Hoists
- Platform Accessories
- Electrical Accessories
- Fall Protection Equipment

To learn more about our products, contact your nearest Power Climber™ dealer:



© 1999 A Division of SafeWorks, LLC
Printed in USA on Recycled Paper